

SMALL CYLINDER LOW/MEDIUM-FREQUENCY
CRYSTAL UNIT

C-4-TYPE

- Photolithography finished allows uniform and stable performance.
- Small and light weight. (ø1.5 x 6mm)
- Excellent shock resistance and environmental capability.
- Most suitable for pagers and card products like PCMCIA.

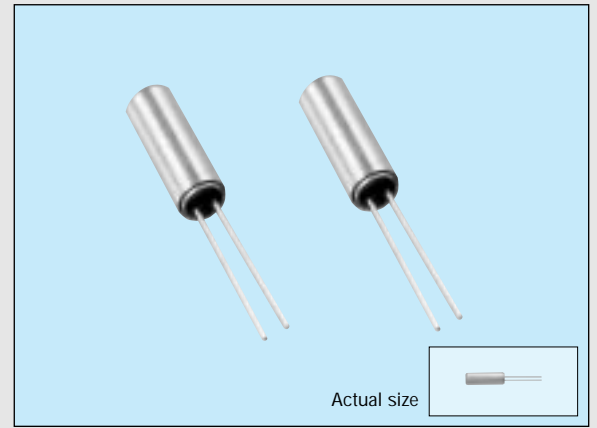

Specifications (characteristics)

Item	Symbol	Specifications	Remarks
Nominal frequency	f	32.000 kHz to 120.000 kHz 192 kHz	Please refer to frequency list below
Temperature range	Storage temperature	T _{STG}	-20°C to +70°C
	Operating temperature	T _{OPR}	-10°C to +60°C
Maximum drive level	GL	1.0μW max.	
Recommended drive level (characteristics)	DL	0.1μW typ.	
Soldering condition	T _{SOL}	Under 280°C with in 5 sec.	Do not heat the package at more than 150°C
Frequency tolerance (standard)	Δf/f	±50ppm, ±100ppm	T _a =25°C, DL=0.1μW
Peak temperature (frequency)	θT	25°C ±5°C	
Temperature coefficient (frequency)	a	-0.04ppm/°C ² max.	
Load capacitance	C _L	6pF to ∞	Please specify
Series resistance	R ₁	32 kHz ≤ f < 40 kHz: 55 kΩ max. 40 kHz ≤ f < 60 kHz: 30 kΩ max. 60 kHz ≤ f < 70 kHz: 25 kΩ max. 70 kHz ≤ f ≤ 100 kHz: 22 kΩ max. 100 kHz < f ≤ 120 kHz: 15 kΩ max. 192 kHz: 10 kΩ max.	
Motional capacitance	C ₁	3.0fF max.	
Shunt capacitance	C ₀	1.5pF max.	
Insulation resistance	IR	500 MΩ min.	
Aging	f _a	±5ppm/year max.	T _a =25°C±3°C, first year
Shock resistance	S.R.	±5ppm max.	Three drops on a hard board from 75 cm or excitation test with 3000G x 0.3ms x 1/2 sine wave x 3 directions

Frequency example

Type	Frequency	C _L Value	
C-2-TYPE	26.6667 kHz	10.0pF, 11.0pF	
	32.5600 kHz	7.0pF	
	36.8640 kHz	13.5pF	
	38.4000 kHz	10.0pF	
	44.7340 kHz	10.0pF	
	48.0000 kHz	15.0pF	
	75.0000 kHz	6.5pF, 9.0pF, 20.0pF	
	77.5030 kHz	10.0pF, 20.0pF	
	76.8000 kHz	6.0pF, 10.0pF, 11.0pF	
	96.0000 kHz	6.0pF, 8.4pF, 11.0pF	
	153.6000 kHz	11.0pF	
	307.2000 kHz	11.0pF	
	C-4-TYPE	38.4000 kHz	11.0pF
		50.0000 kHz	9.0pF
76.8000 kHz		11.0pF	
77.5030 kHz		10.0pF	
	192.0000 kHz	11.0pF	

External dimensions

(Unit: mm)

Model	L ₁	L ₂	D ₁	D ₂	B
C-2-TYPE	6.0 max.	4.0 min.	ø2.0 max.	ø0.2	0.7
C-001R	8.0 max.	9.0 min.	ø3.1 max.	ø0.3	1.1
C-002RX	6.0 max.	4.0 min.	ø2.0 max.	ø0.2	0.7
C-004R	5.0 max.	4.0 min.	ø1.5 max.	ø0.2	0.5
C-005R	4.6 max.	4.0 min.	ø1.2 max.	ø0.15	0.3
C-4-TYPE	5.0 max.	4.0 min.	ø1.5 max.	ø0.2	0.5

(160 to 165kHz, 307.2 kHz: D₁=ø2.2 max.)

THE CRYSTALMASTER



ENERGY SAVING EPSON

EPSON offers effective savings to its customers through a wide range of electronic devices, such as semiconductors, liquid crystal display (LCD) modules, and crystal devices. These savings are achieved through a sophisticated melding of three different efficiency technologies.

Power saving technology provides low power consumption at low voltages.

Space saving technology provides further reductions in product size and weight through super-precise processing and high-density assembly technology.

Time saving technology shortens the time required for design and development on the customer side and shortens delivery times.

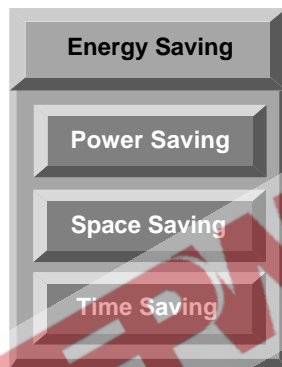

Our concept of Energy Saving technology conserves resources by blending the essence of these three efficiency technologies. The essence of these technologies is represented in each of the products that we provide to our customers.

In the industrial sector, leading priorities include measures to counter the greenhouse effect by reducing CO₂, measures to preserve the global environment, and the development of energy-efficient products. Environmental problems are of global concern, and although the contribution of energy-saving technology developed by EPSON may appear insignificant, we seek to contribute to the development of energy-saving products by our customers through the utilization of our electronic devices. EPSON is committed to the conservation of energy, both for the sake of people and of the planet on which we live.



SEIKO EPSON CORP. QUARTZ DEVICE DIVISION acquired ISO9001 and ISO14001 certification by B.V.Q.I. (Bureau Veritas Quality International) .

ISO9001 in October, 1992.

ISO14001 in November, 1997.

NOTICE

No part of this material may be reproduced or duplicated in any form or by any means without the written permission of Seiko Epson. Seiko Epson reserves the right to make changes to this material without notice. Seiko Epson does not assume any liability of any kind arising out of any inaccuracies contained in this material or due to its application or use in any product or circuit and, further, there is no representation that this material is applicable to products requiring high level reliability, such as, medical products. Moreover, no license to any intellectual property rights is granted by implication or otherwise, and there is no representation or warranty that anything made in accordance with this material will be free from any patent or copyright infringement of a third party. This material or portions there may contain technology or the subject relating to strategic products under the control of the Foreign Exchange and Foreign Trade Control Law of Japan and may require an export license from the Ministry of International Trade and Industry or other approval from another government agency.